

# Polytrend

# Polytrend

Neonatal Incubators





Polytrend

# Polytrend





# Polytrend

## The best technology for Sub-Intensive and Intensive Care



For the last 60 years GINEVRI srl has been designing and manufacturing neonatal incubators which are, and always have been, distinguished by their innovative technical solutions and for their cutting edge performance, in addition to their reliability and extreme simplicity of use, cleaning and sterilization.

In summary:

- UNBREAKABLE & LIGHT WEIGHT of the hood, base and other main components all made in POLYCARBONATE;
- GREATLY REDUCED RISK OF INFECTION, with the capacity to totally dismantle the incubator for complete cleaning and sterilization;
- SPACIOUS HOOD, extremely transparent, with two main doors which open upwards or downwards (optional) and six access portholes;
- WIDE PATIENT TRAY, with the possibility to add the scale, which can be adjusted in the Trendeleburg and Antitrendeleburg positions;
- ELECTRONIC SERVO-CONTROL AND MONITORING OF: temperature, both of the air and skin, relative humidity and oxygen concentration;
- MONITORING: weight, hearth rate and oxygen saturation in the blood.

# Polytrend

## Control Panel – simple and intuitively evident

The control panel, equipped with a LCD display screen to show all the parameters readings and settings is completely microprocessor controlled.

The practical rotational "encoder" on the control panel facilitates the setting of all the different parameters and access to all the various display screens which include:

- The Main screen;
- The Menu screen;
- The Settings screen;
- Trend: air temperature, skin temperature, peripheral skin

temperature, difference between skin and peripheral temperature, difference between air and skin temperature, relative humidity, weight, oxygen concentration, heart rate and SpO<sub>2</sub> (with graphics in 3, 6, 12, 24, 48 hours or 7 days).

The POLYTREND incubator's control panels (as with the previous Polycare models) are designed to be interchangeable; which permits the transition from Super Intensive Care to Intensive Care and then to Sub-Intensive Care by the simple procedure of changing the control panel, all without having to move the little patient from the incubator which first received him, thus avoiding risks of trauma and contamination.

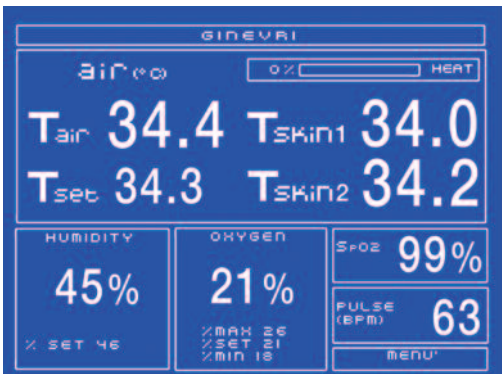

Main Screen



Trend Screen



### REMOTE MONITOR

The POLYTREND incubators are equipped with a 10.4" colour monitor to allow for observation at a distance of the little patient's parameters (optional).

# Polytrend

## Practical Qualities

The awareness that medical treatment and care equipment, beyond the fundamental protection and promotion of the patient's health, must also, when possible, simplify the medical care operator's life and not complicate it has guided the research and design for the assembly of our incubators. In fact, all the functions and procedures which care personnel need to carry out in the course of neonatal assistance, from cleaning and disinfection after use to technical assistance, have been designed to be straightforward, practical and easy to carry out. The wires for connecting the various functions to the control panel are fitted with error free plugs. This allows the incubator

to be totally disconnected in just a few minutes and without any tool. This in turn, allows for comfortable and complete sterilization of all the components which are unbreakable, washable, sterilizable, durable and crushproof. These qualities all derive from the LEXAN POLYCARBONATE material with which they are pressure injection stamped in single pieces. This last characteristic of being stamped in single pieces contributes to the efficient air circulation for the optimum micro climate inside the hood and also to the reduction of noise inside the incubator and, finally, to the aesthetics of the hood itself. X-Ray cassette, integrated in the base, allows performing radiographic examination without having to move the newborn from the incubator.

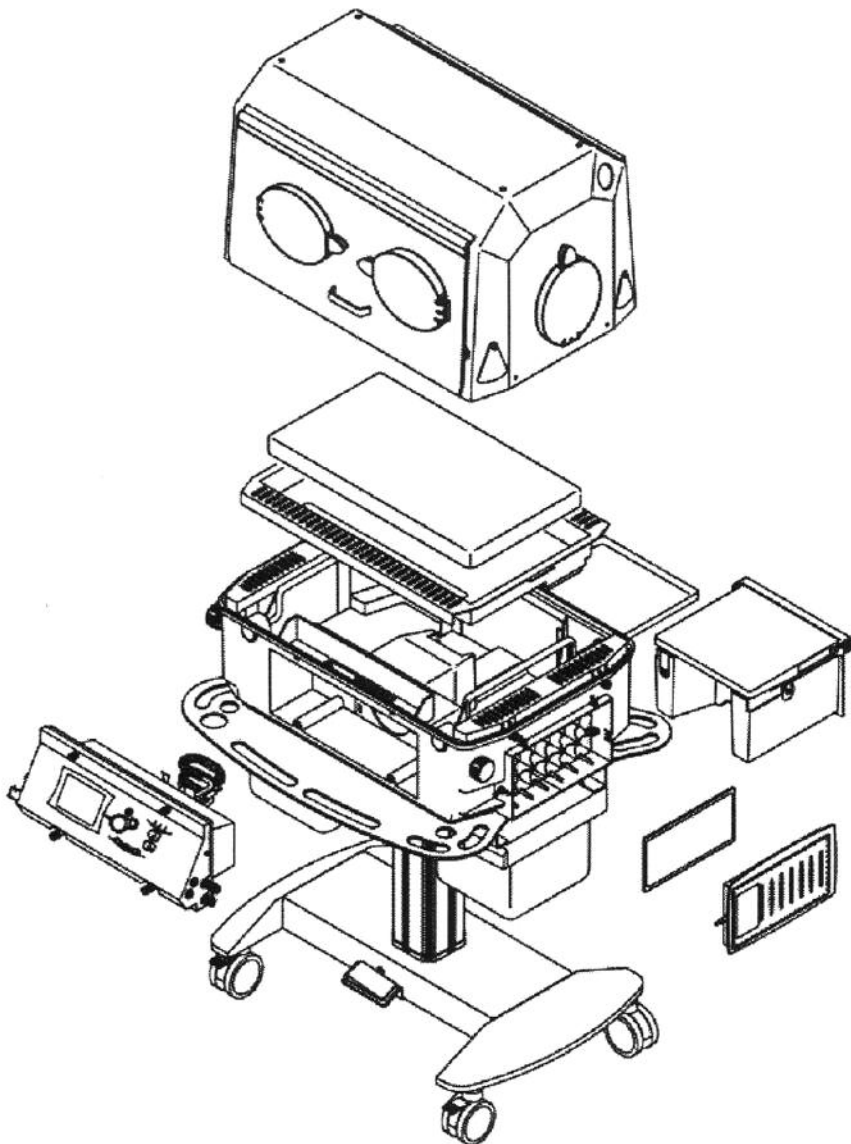



**OPERATING:** The external ambient air, eventually enriched with oxygen, enters the incubator passing through a high capacity micro-filter (less than  $0,5 \mu\text{m}$ ) located on the base. A special fan sucks air from outside (with oxygen if necessary) and pushes it into the heating chamber and air, after having passed through the humidifier, flows in the hood through the specially provided slits without causing dangerous turbulence around the newborn. The best solution, scientifically approved is the one applied on our incubators, where air required for the elimination of  $\text{CO}_2$  enters and

exits from the hood through 118 slits located on the perimeter of the bed. This gives to the microclimate a low speed and flow, thanks to the particular aero-dynamical study of the incubator hood, slipping along the walls, creates a "bubble of warm and moist air" around the newborn. In this way the internal side of this bubble exchange the necessary moist heat with the newborn, meanwhile the external side, which is hotter, limits the heat loss (substituting the double wall) ensuring, at the same time, the removal of the  $\text{CO}_2$  produced by the baby itself.

N°118 slits



Air circulation without double wall

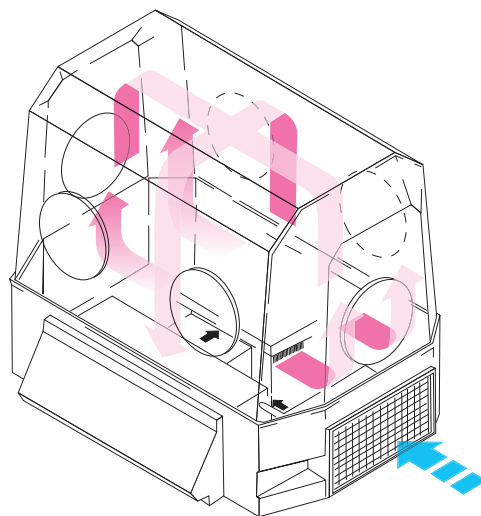

Bubble of warm and moist air

The bond between polycarbonate and injection molding has generated a unique incubator, light and extremely practical both to protect and promote health of the newborn.

The incubator also works without oxygen. In this way, it can be assured to the newborn the appropriate blood oxygen saturation with 21% of dissolved oxygen in the air.

# Polytrend

## An Innovative and Practical Hood

The hood is made from polycarbonate in a single piece. It has two main doors for total opening; it has six access portholes with soundproof opening and equipped with gaskets and sleeves to prevent leak of temperature and humidity, when they are opened. In addition, in the hood itself there are pre-made channels for passing the wires and tubes necessary to connect the little patient to external medical devices.

There are several possible openings:

- Upwards with alloy hinge;
- Downwards and Upwards with alloy hinge (optional);
- Downwards with special hinge;
- Upwards with special hinge.

The upwards doors allow to prevent the cross infections.

The downwards doors with special hinges are characterized by specific swivel devices that allow to compensate the prominence of the control panel and some optional accessories.

The hood is easily removable from the base so as the doors.



Downwards;

The very spacious hood allows operating on the newborn even when it is covered by a tangle of cables, wires, tubes etc.



Upwards;

This prerogative, extremely functional, allows operating in emergency situations keeping the little patient in a secure environment without need for equipment hybrid and bulky.

### OTHER FEATURES OF THE HOOD

- Compact molecular structure (it helps the slipping of the microclimate on the walls);
- Full transparency;
- Non-flammable and self-extinguishing;
- Do not hygroscopic;
- Unbreakable, lightweight, easy to handle;
- Non-toxic, can not be attacked from oil, grease and normal disinfectants;
- Easily removable for cleaning, washing and disinfection.



## Humidification and Oxygenation

### Humidification

All incubators in the POLYTREND series include a standard humidifier. This is made up of a basin for keeping water and a device to manually adjust the humidity level. Both the basin and the above mentioned unit are made of pressure stamped polycarbonate.

The basin is transparent and can be easily taken out to allow the water to be changed, cleaning or sterilization, without moving the patient from inside the incubator.

The models which are equipped with humidity servo-control use a peristaltic pump and a heater to withdraw water from a reservoir, placed outside the incubator, and emit STERILE VAPOR into the hood at levels independent from the operational temperature.

As the standard humidifier also the servo controlled one is easy to disassemble, clean and sterilize.



### Oxygenation

All incubators in the POLYTREND series are furnished with a standard unit consisting of two inlets for oxygen, incorporated in the assembly holding the micro filter. The internal one allows reaching a maximum concentration of 31%; whereas the external one allows up to 52%.

Obviously the models which have the oxygen servo control (up to 95%) have a dedicated oxygen inlet that enables concentration up to 100% in the special oxygen hood (optional).

For safety reasons, the oxygen concentration in the hood, upon a request, may be limited to values no higher than 65%. Greater values, up to and beyond 95%, can be achieved in a special oxygen hood with lightweight plastic bed sheet (optional) placed inside the hood. Consequently we reduce the volume that has to be saturated with a lower consumption and less risk.



O<sub>2</sub> inlet up to 31%

O<sub>2</sub> inlet up to 52%

Servo controlled O<sub>2</sub> inlet up to and beyond 95%

Servo controlled O<sub>2</sub> outlet up to and beyond 95% for oxygen hood



# Polytrend

## Patient Tray

The PATIENT TRAY is:

- Made of polycarbonate in one single piece;
- Wide with the mattress;
- Perfectly connected and with all surfaces smooth;
- Unbreakable, anti-fire, self-extinguishing;
- Permits to measure the patient both in centimeters and inches;
- Easily removed to allow for complete thorough cleaning and sterilization;

- The entire perimeter permits the flow of hot air which, in this way, creates not only a perfect micro climate circulation but also a protective barrier for the little patient when the doors are open;
- Supported by a special Smooth Tilt device for continuous inclination adjustment ( $\pm 12^\circ$ ) in the Trendelenburg and Antitrendelenburg position, and to be taken out from the incubator for particular operations, without making it fall or slip.



## Scale

- BILLA, electronic baby scale complies to Directive 93/42/CEE

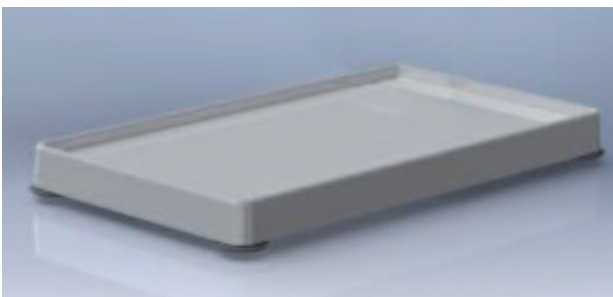

- BILLA, electronic baby scale complies to Directive 93/42/CEE and NAWI

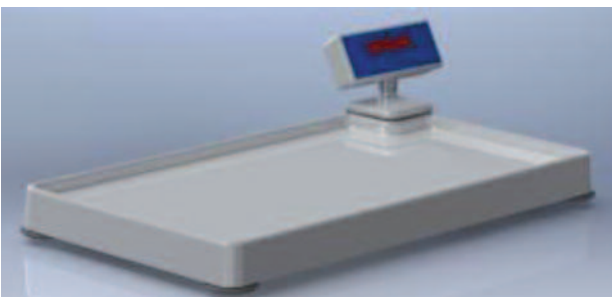

The scale (optional) is integrated in POLYTREND incubator and is completely managed through the control panel. Complies with Directive 93/42/CEE. The scales, upon request, can be certified NAWI.

The scale is integrated in our incubators and it allows performing x-ray imaging, measurement and storage of the weight.

The range of measure goes from 0 g to 10000 g.

It is possible to visualize variations of the patient weight in real time, calculate the tare, and see graphical trends of the last 3h, 6h, 12h, 24h, 48h, 7 days.

It is possible to make zero of the scale at any time enabling the automatic procedure and lifting the newborn from the bed for a few seconds (15 sec).

The weight can be also measured with bed in a inclined position (Trendelenburg and Antitrendelenburg).

# Polytrend

## Trolleys, Accessories and Consumables

The trolleys, with their innovative and ergonomic design, are made of treated stainless steel. The base's side panels are made of polycarbonate and the handles are fabricated with stainless steel also, resistant to inevitable bumps and scrapes. On both the short

sides sliding service trays can be equipped. Service drawers can also be equipped below the trolley. The trolley can be either height adjustable by a foot pedal control, which can also be installed on both sides, or fixed height.



IV Pole



Microclimate hood with bed sheet



UPS



Skin probe



Remote Monitor

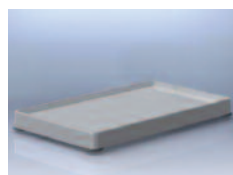

BILLA Scale



Integrated Pulse Oximeter (NELCOR technology)



Oxygen Sensor



Drawer



Shelf



Air filters



Gel Sticker (2 and 3 cm diameter) (24pcs)



# Polytrend

## Technical Specifications

MODEL	POLYTREND
CE MARK	Yes
MOBILE OR TRANSPORT	Mobile
TEMPERATURE CONTROL	
Air:	Servo control
Range (increments):	20-37°C override 39°C (0.1°C)
Skin:	Servo control
Range (increments):	25-37°C override 39°C (0.1°C)
TEMPERATURE DISPLAY	LCD
Air temp.:	Range: 12 - 45 °C
Skin temp.:	Range: 12 - 45 °C
Peripheric skin temp.:	Range: 12 - 45 °C
TRENDS VISUALIZATION	Air Temp., Skin Temp., Peripheral Skin Temp., Relative Humidity, Oxygen Concentration(opt), Weight(opt), SpO2 (opt), Heart rate (opt)
RELATIVE HUMIDITY DISPLAY	LCD
	Range: 10 - 99 %
RELATIVE HUMIDITY CONTROL	Optional
	Range: 15 - 95 %
OXYGEN CONCENTRATION DISPLAY	LCD
	Range: 21 - 99 %
OXYGEN CONCENTRATION CONTROL	
O <sub>2</sub> inlet ports/ controllers:	2/ maximum 31% and 52%
Servo control (OPTIONAL):	Range: 21 - 65 % in incubator hood Range: 21 - 100 % in oxygen hood
ALARMS - VISIBLE AND ACOUSTIC	
Low heart rate	Optional
High heart rate	Optional
Low SpO <sub>2</sub>	Optional
High SpO <sub>2</sub>	Optional
High air temperature	Yes
Low air temperature	Yes
High skin temperature	Yes
Low skin temperature	Yes
Fan failure	Yes
Air probe failure	Yes
Skin probe failure	Yes
Probe disconnection	Yes
Max temperature	Yes
Power failure	Yes
High oxygen concentration	Optional
Low oxygen concentration	Optional
High humidity	Optional
Low humidity	Optional
SpO <sub>2</sub> - Heart rate	Optional
BACKUP THERMOSTAT	Yes
HEATER POWER INDICATOR	Vertical bar, 10% increments
HAND PORTS	2 main doors, 6 port holes
TUBING PORTS	2 respiratory, 7 accessory
PHOTOTHERAPY	Optional
INTERNAL NOISE	42 dB
LINE POWER	230Vac 50/60 Hz
INTERNAL BATTERY	4.8 V backup for power failure alarm
DOUBLE WALL	Optional
BABY SCALE	Optional
DIMENSIONS	
Incubator, W x D x H	83 x 64 x 69 cm
Fixed height Trolley, W x D x H	86 x 70 x 70 cm
Height adjustable Trolley, W x D x H	86 x 70 x (63 - 83) cm
Vertical hood to mattress distance	45 cm
Mattress, W x D	62 x 35 cm
Castors diameter	10 cm
WEIGHT	
Incubator	37 kg
Fixed height Trolley	41 kg
Height adjustable Trolley	55 kg



## Quality System

ISO 9001:2008  
ISO 13485:2012



The specifications in this catalogue are indicative. The company GINEVRI srl reserves the right to make changes, without further notice, to the products described within this catalogue in order to improve reliability, function or design.

8070BCB rev.05

**GINEVRI**

Quality for life

GINEVRI srl  
Via Cancelliera, 25/b  
00041 Albano Laziale  
(Rome) - Italy  
Tel.: +39 06 93459 330  
Fax: +39 06 93 459 393  
e-mail: [export@ginevri.com](mailto:export@ginevri.com)  
[www.ginevri.com](http://www.ginevri.com)

Authorized Distributor

